

## Installation instruction for Carplay Android Auto interface



### AUDI, MIB1/MIB2 interface

The interface is connected via a power and video cable to the radio. It is estimated 30-45 minutes of work to connect the interface. No programming required.

#### **Step 1. Turn off the ignition**

By turning off the ignition, there is no more power on the multimedia unit and the cables can be safely disconnected and connected.

#### **Step 2. Disconnect the multimedia player**

Using the release keys, pull the multimedia unit forward. Insert the keys into the slots with the straight side on the outside and not too deep. If the keys are too deep, the unit will not come out.



Disconnect the large black power connector from the multimedia unit by pressing the tab of the plug, pressing the handle down slightly, and then pulling it over. The power connector will then come out automatically.



Press the pallet from the grey or pink video connector on the bottom. Very carefully pry a small flat object between the seam if the plug is very tight. Leave the rest of the plugs plugged in. If necessary, cut some tape between the cables so that there is enough freedom of movement to be able to pull the thick cable and the video cable out of the housing.

***Step 3. Remove the side panel from the dashboard***

Click the right side panel away from the dashboard.



***Step 4. Remove the glove compartment***

Unscrew the 8 pieces of 8mm bolts so that the glove compartment comes loose in its entirety. 1 Bolt is on the side, 2 bolts on the bottom, 3 on the top, 1 behind the multimedia player in the top left corner and 1 in the top right corner on the inside. Lower the glove compartment. Most convenient is to remove the bolt in the middle of the top as the last one.



**Step 5. Connect the interface connection cable**

Pull the original power connector of the multimedia unit out of the compartment and connect it to the socket of the interface connection cable.

Depending on the type of cable, there may be an optical plug in the square power strip. This can be recognized by two round holes instead of two pluses in the red circle (see image).



Remove this optical plug by pressing the tab and gently pulling the plug out of the power strip with the orange or green optical cables. Press the optical plug into the same position in the other power strip with lever.

*Note: (orange or green) optical cables do not kink or damage!*

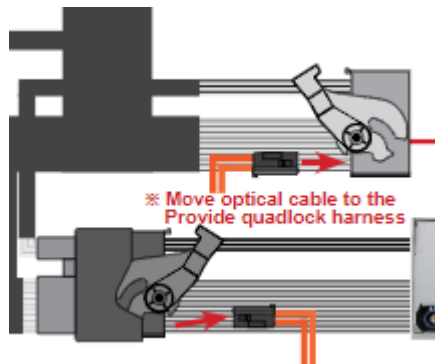

*transfer optical plug (if equipped)*

If necessary, cut the tape of the optical plug slightly away from the original wiring harness to ensure that the large power strip has sufficient length to be able to reconnect to the multimedia unit.

### **Step 6. Connect the interface video cable**

Unplug the multimedia unit video cable from the compartment and connect it to the interface video cable socket.

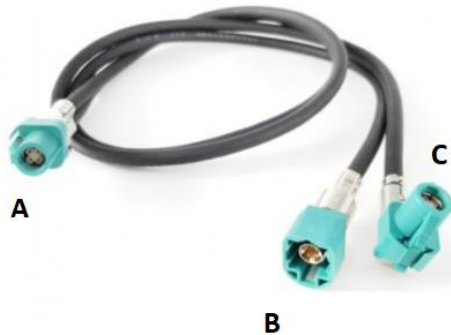

**Plug A** has a double cable. This plug goes on the interface (otherwise black screen). Connect **plug B** of the video cable to the socket of the video cable coming from the multimedia unit.

### **Step 7. Reconnect the multimedia unit**

Pull the daisy-chained power strip and **video plug C of the video cable** back into the multimedia unit compartment and plug it back in (plug C on the pink or grey connector). Check that all plugs are securely attached and press the multimedia unit back into the housing (do not click into place yet). Do not push through in case of resistance, but make room by pulling the cables back from the outside. The connected square power strip is located on the outside of the compartment. There is enough space to hide the power strip.

### **Step 8. Insert the antenna**

*Black-colored interface:*

Stick the Wi-Fi antenna in a free space against plastic (not on metal or the interface itself).

*Silver interface:*

Turn both antennas on the unit.

### **Step 9. Position the USB cable**

Determine the most desired position of the USB plug. Guide the USB extension cable to that position, for example along or behind the plastic cover plate of the air filter in the back of the glove compartment.

### Step 10. Connect all cables

Connect all cables to the interface (antenna, power supply, USB, video plug A).

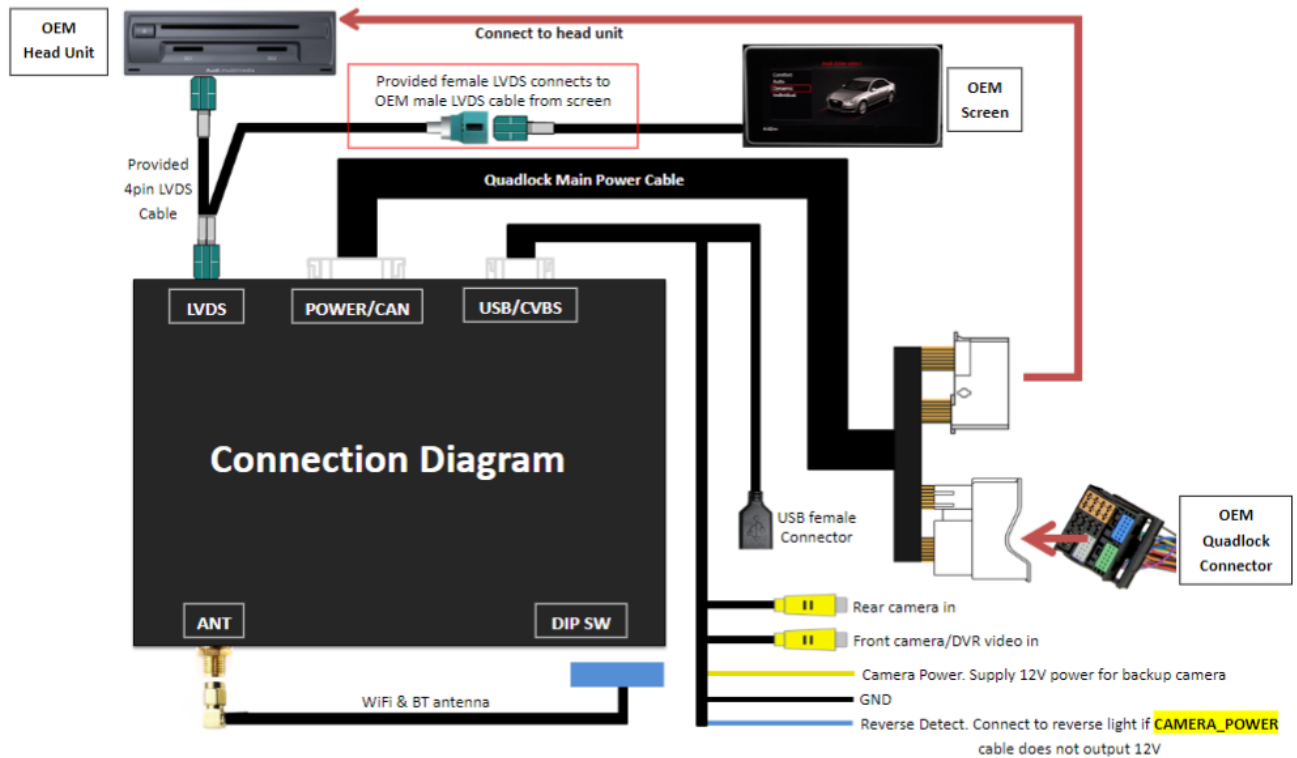

### Step 11. Test the system

Test the system for at least the following:

- graphics
- sound
- switch between radio and interface (back, media or nav button few sec presses)
- acceleration in reverse
- calling

*Tip: Press the "BACK, MEDIA or NAV" button for 10 seconds for a reboot of the interface.*

For sound, the radio must first be set to AUX or AMI. If there is no sound, this port needs to be activated. This is possible via the optional AMI-AUX cable or, in extreme cases, programming this function at the dealer.

Check the position of the dip switches in case something does not function properly. After changing a dip switch, the power must be removed from the unit (power plug out/in).

### ***Step 12. Mount the interface***

If everything is working properly, mount/paste the interface on top of the glove compartment. Make sure the vents remain free. Permanently snap the multimedia unit.

### ***Step 13. Rebuild the system***

Screw the glove compartment back into position and snap the side panel back into position. At the bottom there are ventilation ducts, first position them well in relation to the openings.

*Note: Push the cables away in the available space and make sure that they cannot get trapped or sit in front of a screw hole!*

### ***Step 14. Connect the interface to your phone***

Disconnect and forget the Bluetooth connection to the AUDI. Connect to the Bluetooth of the Carplay interface and turn on Wi-Fi and Carplay on your phone. The interface builds up a Wi-Fi connection itself via the Bluetooth connection. The system is basically ready.

### ***Step 15. Enjoy!***



*This manual has been compiled on the basis of experience and with the necessary care. No rights can be derived from it. Improvement tips/tricks are of course always welcome! ([motrade@kpnmail.nl](mailto:motrade@kpnmail.nl))*